

SPECIFICATIONS:

POWER SUPPLY REQUIREMENTS: + 10 VDC minimum with suffix AAA = 100
 The maximum power supply voltage is + 30 volts DC. The positive supply at terminal number 1 must deliver a minimum of 40 ma. plus the output valve coil current requirement.

EXTERNAL COMMAND SIGNAL: + 3 volts dc with suffix BBB = 030
 + 5 volts dc with suffix BBB = 050 + 10 volts dc with suffix BBB = 100

INPUT IMPEDANCE AT TAB "A": 60K ohms with suffix BBB = 030
 100K ohms with suffix BBB = 050 200K ohms with suffix BBB = 100

INPUT IMPEDANCE AT TAB "W": 100K ohms with all BBB suffix identifiers

RATED OUTPUT CURRENT: + 250 ma. with suffix CCC = 251
 + 500 ma. with suffix CCC = 501 + 1000 ma. with suffix CCC = 102
 + 2000 ma. with suffix CCC = 202 + 3000 ma. with suffix CCC = 302
 + 4000 ma. with suffix CCC = 402 + 5000 ma. with suffix CCC = 502
 The absolute output current must not exceed 8 amps under any operating condition.

OUTPUT CURRENT LIMIT: The exact current limit value is dependant upon the valve coil inductance and the switching frequency. In general, the current limit will be approximately 150% of the rated output current as defined by suffix CCC.

PWM SWITCHING FREQUENCY: 100 Hz. with suffix D = 1
 200 Hz. with suffix D = 2 400 Hz. with suffix D = 3
 1000 Hz. with suffix D = 4 2200 Hz. with suffix D = 0
 The pulse width modulated (PWM) switching frequency tolerance is plus and minus 20% of the value shown.

MINIMUM CURRENT ADJUSTMENT RANGE: 0% to 40% of the rated output current.

MAXIMUM CURRENT ADJUSTMENT RANGE: 75% to 100% of the rated output current.

STABILITY AND DRIFT: Better than 1% of maximum with inner loop current feedback.

OPERATING TEMPERATURE RANGE: - 20 degrees C to + 55 degrees C.
 Extended temperature range operation is available, contact Datatran's Sales Department for availability and price.

OUTLINE DIMENSIONS:

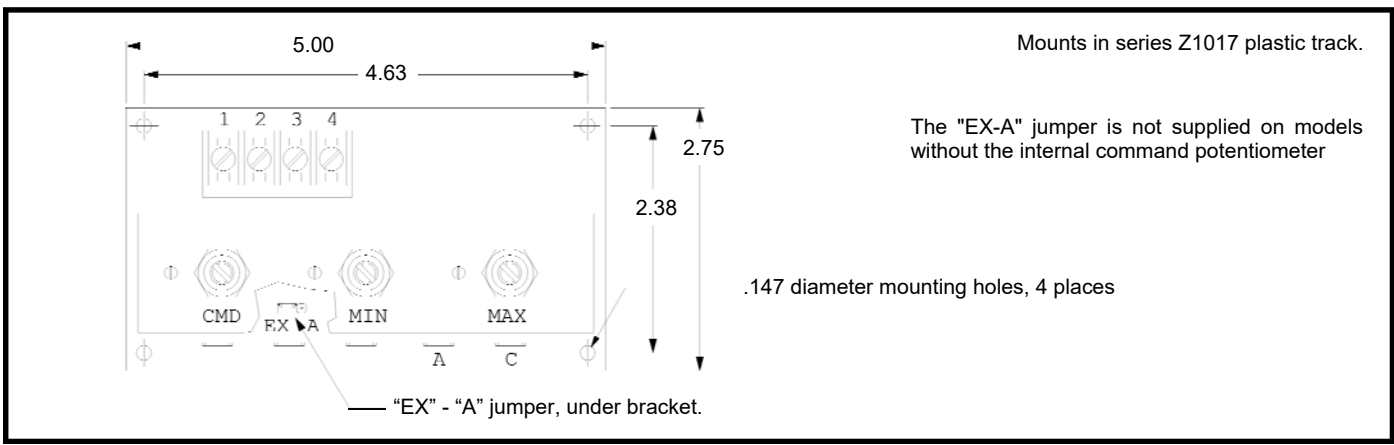

GENERAL DESCRIPTION:

This pulse width modulated valve driver module is designed to be used for open loop motion, speed and pressure control systems. The output is unipolar and will drive all single solenoid proportional and servo valves that have coil current requirements up to 5 amps. The command signal can be obtained from either a potentiometer or an external voltage source.

This industrial grade module is a true high performance current regulator. It incorporates current loop feedback to maintain the output signal to the valve coil within 1% of the setpoint as the load impedance, input voltage, and ambient temperature are varied over the specified operating range. Pulse width modulated switching provides high efficiency as the output current is varied from minimum to maximum.

Each pulse width modulated valve driver module includes an optional internal command potentiometer as well as the controls required to set the minimum and maximum output for the valve coil current. The module contains provisions for the use of an external command potentiometer or the ability to follow a remote command voltage signal. The output current to the valve coil will vary from the minimum to the maximum as the input signal is adjusted from zero to the rated value. The module requires a positive 10 to 30 volt DC power supply for operation.

The circuit board is solder masked. All external power and valve coil connections are made to a barrier type terminal block with #6-32 captive wire clamping plates. External command signals are made to .25 inch male tabs. All external connections are clearly marked on the board.

PART NUMBERING SYSTEM:

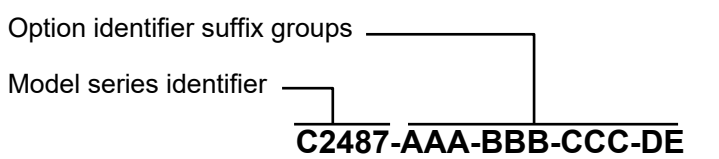

PART NUMBER SUFFIX GROUP EXPLANATION	
SUFFIX	DESCRIPTION
AAA	Minimum power supply voltage
BBB	Maximum input signal voltage
CCC	Maximum output current to valve coil
D	Pulse width modulated switching frequency
E	Factory installed option identifier

Parts shipped from the factory will have the correct alphanumeric option identifier in place of the suffix letters indicated in the table above.

ORDERING INFORMATION:

Refer to the C2478 model series selection sheet for a complete listing of the currently available models.

**DATA SHEET
 FOR
 DATATRAN
 C2478
 PULSE WIDTH
 MODULATED VALVE
 DRIVER BOARD
 (SINGLE SOLENOID)**

**FOR TECHNICAL ASSISTANCE CONTACT
 CONIC SYSTEMS INC.
 11 REBEL LANE, PORT JERVIS, NY 12771
 TEL: (845) 856-4313 FAX (845) 858-2824
 www.conicsystems.com**

APPLICATION INFORMATION:

LOAD IMPEDANCE: The maximum and minimum output load resistance can be calculated from the formulas given below:

$$Z(\text{Load maximum}) = \frac{\text{Power supply voltage} * 2}{\text{Rated load current} * 3}$$

$$Z(\text{Load minimum}) = \frac{\text{Power supply voltage} - 1}{8}$$

The formula given for the maximum load resistance assumes a triangle shaped waveform. This waveform is integrated by the valve coil inductance to produce the equivalent dc operating current. Depending on the coil inductance, some valves

!!!! CAUTION !!!!

Minimum load impedances less than those given by the formula above may cause the valve driver to fail as a short circuit. This will apply the full power supply voltage to the connected load.

may operate with coil resistance greater than that given in the formula.

SIGNAL SELECT (EX-A) JUMPER: When the valve driver is supplied with the internal command potentiometer, it will also include a signal source select jumper. This jumper is a three position pin header and shorting bar located under the bracket. It is marked "EX-A". This jumper is used to select the input signal source, either the internal command potentiometer or an external command potentiometer or voltage source can be used as the input signal. The jumper position depends on the signal source as described in the sections below. Valve drivers supplied without the internal command potentiometer will not have the signal select jumper installed.

EXTERNAL VOLTAGE COMMAND SIGNAL: The valve driver is capable of following an external voltage signal. This signal should be applied to tabs "A" and "C". The common (0 volt) side of the external signal must be connected to tab "C". The "EX"-A" jumper must be removed or placed in the "A" position. Note that the external signal and the amplifier must share the same reference potential. The valve driver does not provide signal isolation.

EXTERNAL COMMAND POTENTIOMETER: The valve driver can be used with a remote command potentiometer. This potentiometer uses the amplifiers internal +5 volt reference and should be connected to tabs "H", "L" and "W". In the event that this option is used the "EX"-A" jumper must be removed or placed in the "A" position. The internal command potentiometer, if installed, is disabled.

User supplied external command potentiometers should have a linear taper with a value between 1000 and 5000 ohms and be rated .5 watt, minimum.

INTERNAL COMMAND POTENTIOMETER: The valve driver can be supplied with a built in command potentiometer mounted on the module. In the event that this potentiometer is used to set the amplifier output the "EX"-A" jumper must be placed in the "EX" position.

INTERNAL REFERENCE VOLTAGE: A nominal +5 volts DC is available at tab "H" for powering external loads. The maximum output current from this supply must be limited to 10 ma.

PULSE WIDTH MODULATED SWITCHING FREQUENCY: The switching frequency is specified by the number inserted at suffix D. Standard switching frequencies of 100, 200, 400 1000 and 2200 Hz. are available. Generally, the proportional valve manufacturer will specify the pulse width modulated switching frequency for a specific valve. If you require a switching frequency that is not listed as standard you must specify the required frequency on your purchase order. In this case, a special part number will be assigned to the valve driver module. Datatran can supply this module with switching frequencies from 100 to 10,000 Hz. There is no additional charge for this modification.

If you do not know the required switching frequency you should specify 2200 Hz. (suffix D = 0). This frequency will provide adequate performance with almost all proportional solenoids.

The valve driver switching frequency can be measured at test point "TP" with an oscilloscope.

INTRINSICALLY SAFE VALVE COILS: These devices typically contain zener diodes in order to limit the maximum voltage applied to the coil to safe values. The pulse width modulated valve driver is a current regulator and will always apply the full power supply voltage to the coil. In order to provide proper operation and to prevent failure of the internal zener diodes the power supply output must be limited to the rated voltage of the coil used. In general, Datatran's unregulated power supplies are not suitable for this application. Additional information can be obtained from Datatran's engineering department.

EXTERNAL WIRING: External command signals should be twisted and shielded cable. All shields should be terminated at terminal 2 on the amplifier only. Do not expose or connect the shield at any point in its run from the signal source to the valve driver module. Connections to the valve coil need not be shielded, however a reasonable effort should be made to route this cable away from equipment generating electrical noise. For optimum performance, all external connections to the valve driver should be via shielded cable

FUNCTIONAL DIAGRAM:

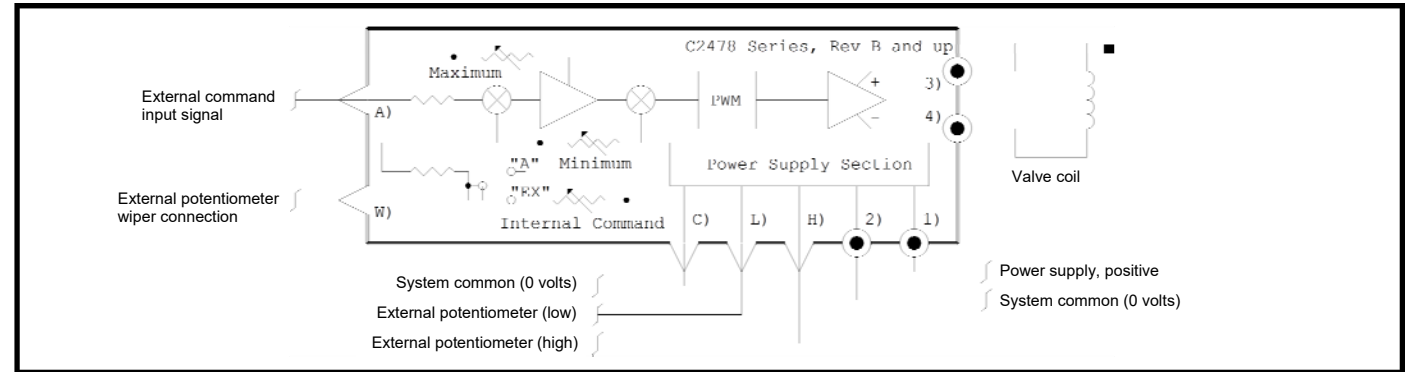

!!!! WARNING !!!!

Do not apply voltages less than the system common (0 volt) value to either the "A" or "W" tabs. Negative voltages applied to the "A" or "W" tab may cause the valve driver to apply the full power supply voltage to the connected valve coil.

APPLICATION EXAMPLES:

Unidirectional, proportional solenoid valve drivers with the setpoint command signal derived from an external command potentiometer or from an external voltage source.

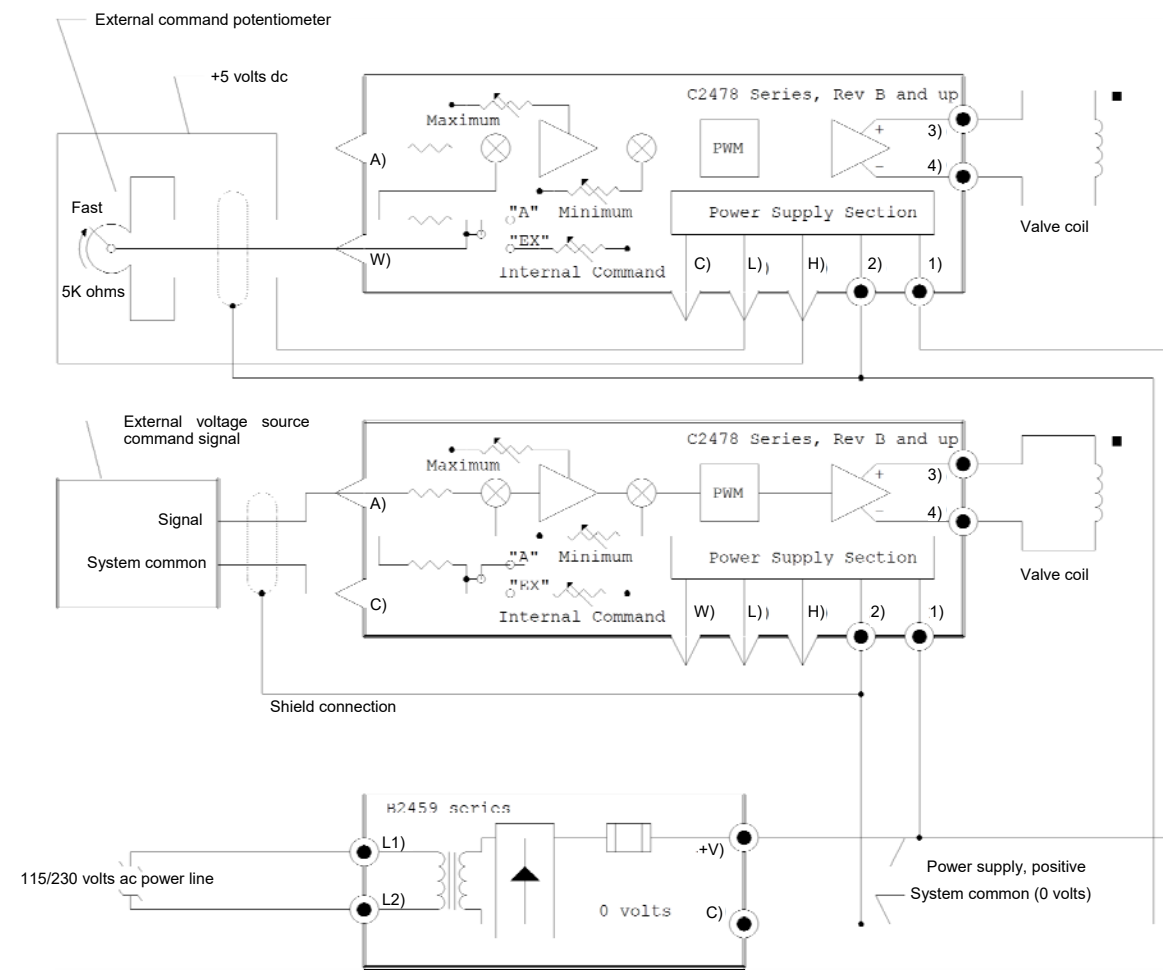

Note that for both examples shown, the "EX-A" jumper is in the "A" position.