

**SPECIFICATIONS:**

<b>POWER SUPPLY REQUIREMENTS:</b>	+/- 10 VDC minimum with suffix AAA = 100 +/- 15 VDC minimum with suffix AAA = 150
The maximum power supply voltage is +/- 30 volts DC. The positive supply at terminal numbers 1 and 3 must deliver a minimum of 40 ma. plus the transducer and output valve coil current requirement.	

<b>TRANSDUCER POWER SUPPLY VOLTAGE:</b>	+/- 8 volts dc with suffix AAA = 100 +/- 12.5 volts dc with suffix AAA = 150
---	---

<b>TRANSDUCER POWER SUPPLY CURRENT:</b>	+/- 250 ma. maximum for each output.
---	--------------------------------------

<b>TRANSDUCER POWER SUPPLY STABILITY:</b>	Better than 1% as the output current varies from 10 to 250 ma.
---	--

<b>REFERENCE POWER SUPPLY VOLTAGE:</b>	+/- 4.98 to +/- 5.01 volts dc for all models.
--	---

<b>REFERENCE POWER SUPPLY STABILITY:</b>	+/- 50 ma. with a 2 ma. load per output. The maximum current from either the plus or minus reference power supply output should be limited to 5 ma.
--	--

<b>EXTERNAL COMMAND AND FEEDBACK SIGNALS:</b>	+/- 3 volts dc with suffix BBB = 030 +/- 5 volts dc with suffix BBB = 050 +/- 10 volts dc with suffix BBB = 100
---	---

<b>RATED OUTPUT CURRENT:</b>	+/- 25 ma. with suffix CCC = 250 +/- 75 ma. with suffix CCC = 750 +/- 150 ma. with suffix CCC = 151	+/- 50 ma. with suffix CCC = 500 +/- 100 ma. with suffix CCC = 101 +/- 200 ma. with suffix CCC = 201
------------------------------	---	--

<b>OUTPUT CURRENT LIMIT:</b>	The current limit will be approximately 150% of the rated output current as defined by suffix CCC.
------------------------------	--

<b>INPUT AND FEEDBACK SIGNAL IMPEDANCE:</b>	Terminal numbers 8 and 9 are 100K ohms each. Terminal number 12 is 4K ohms per rated input volt (suffix BBB). Terminal number 10 and 11 require that external resistance be added in series with the applied signal.
---	--

<b>PROPORTIONAL GAIN ADJUSTMENT RANGE:</b>	.5% to 20% output ma. per 1% input volts.
--	---

<b>INTEGRAL GAIN RANGE ADJUSTMENT:</b>	1% to 42% output ma./sec. Per 1% input volts.
--	---

<b>BIAS ADJUSTMENT RANGE</b>	+/- 50% of rated output current, minimum.
------------------------------	---

<b>INNER LOOP GAIN:</b>	1% output ma. per 1% input volts, fixed.
-------------------------	--

<b>STABILITY AND DRIFT:</b>	Better than 1% of maximum with inner loop current feedback.
-----------------------------	---

<b>OPERATING TEMPERATURE RANGE:</b>	- 20 degrees C to + 55 degrees C. Extended temperature range operation is available, contact Datatran's Sales Department for availability and price.
-------------------------------------	---

**GENERAL DESCRIPTION:**

This series of linear servovalve driver modules is designed to be used for open or closed loop motion and speed control systems. The output is a linear bipolar current signal and will drive all pump displacement control devices and servovalves that have coil current requirements up to 200 ma. The command signal can be derived from either an external voltage source or a potentiometer.

This industrial grade module provides a bipolar current output, with inner loop current feedback that is accurate to 1% as the load impedance, power supply and ambient temperature are varied over the specified range. External feedback devices can be used to improve the load regulation to 1/10% or better.

Adjustments are included on the module for servovalve coil bias or centering, as well as signal gain. The amplifier may be operated in either a proportional or integral gain mode with or without external feedback. The proportional gain mode should be selected for all open loop applications as well as closed loop position, pressure and torque control systems. The integral gain mode should be used for closed loop flow or velocity control applications only. Inhibit connections are provided to disable the integral function. With the integral clamped the output will be held at zero. Also included is an regulated bipolar 5 volt reference supply that can be used to power an external command potentiometer or feedback transducer. The amplifier requires a bipolar 10 to 30 volt DC power supply for operation.

The circuit board is solder masked. All external wiring to the module is made to a clearly marked barrier type terminal block with #6-32 captive wire clamping plates. All external connections are clearly marked on the board.

**PART NUMBERING SYSTEM:**



PART NUMBER SUFFIX GROUP EXPLANATION	
SUFFIX	DESCRIPTION
AAA	Minimum power supply voltage
BBB	Maximum input signal voltage
CCC	Maximum output current to valve coil
DD	Factory installed option identifier

Parts shipped from the factory will have the correct alphanumeric option identifier in place of the suffix letters indicated in the table above.

**ORDERING INFORMATION:**

Refer to the C2405 model series selection sheet for a complete listing of the currently available models.

# DATA SHEET FOR DATATRAN C2405 LINEAR SERVOVALVE AMPLIFIER

FOR TECHNICAL ASSISTANCE CONTACT  
CONIC SYSTEMS INC.  
11 REBEL LANE, PORT JERVIS, NY 12771  
TEL: (845) 856-4313 FAX (845) 858-2824  
www.conicsystems.com

## OUTLINE DIMENSIONS:

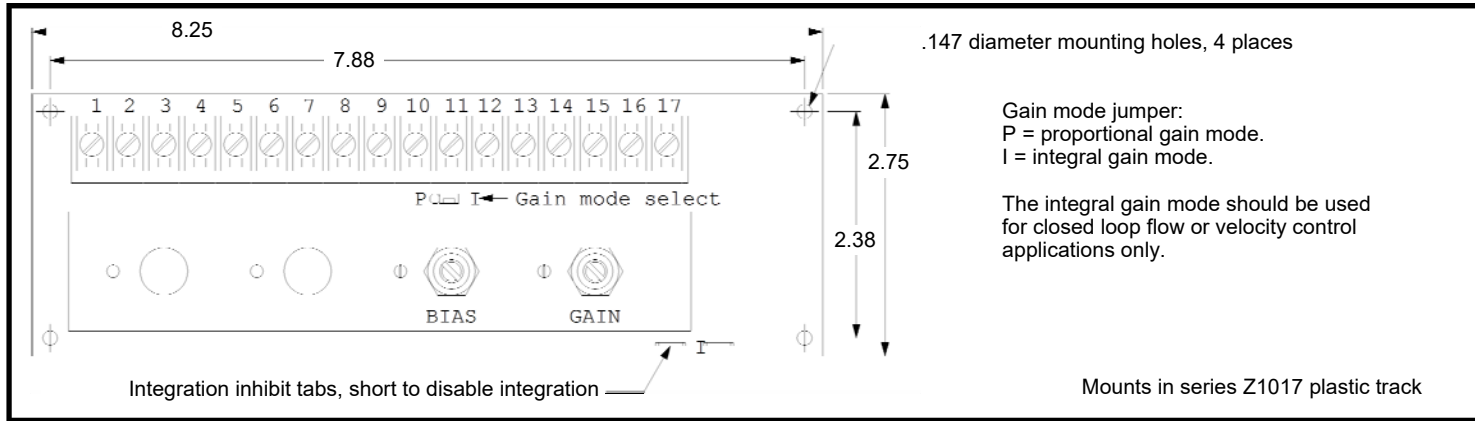

## APPLICATION INFORMATION:

**LOAD IMPEDANCE:** The maximum output load resistance is limited by the amplifier's internal compliance voltage and can be calculated from the formulas given below:

$$Z(\text{Load maximum, in ohms}) = \frac{K}{\text{Rated load current}}$$

$$K = 4.25 \text{ for amplifiers with suffix AAA} = 100$$

$$K = 8.25 \text{ for amplifiers with suffix AAA} = 150$$

**EXTERNAL VOLTAGE COMMAND SIGNAL:** The amplifier is designed to operate with an external voltage command signal. This signal should be applied to terminal number 8. The common (0 volts) side of this signal must be connected to terminal number 15.

**EXTERNAL VOLTAGE FEEDBACK SIGNAL (CLOSED LOOP OPERATION ONLY):** The amplifier is designed to operate with an external voltage feedback signal. This signal must be opposite in polarity to the command signal and applied to terminal number 9. The common (0 volts) side of this signal must be connected to terminal number 15. For open loop applications terminal number 9 should be jumpered to terminal number 15.

**EXTERNAL IMPEDANCE:** The amplifier is capable of operation with command and feedback voltages other than those defined by suffix BBB. These signals are applied to terminal numbers 10 and 11. The user must install an external resistor in series with the input signal. The value for these external resistors can be calculated from the formula below.

$$R(\text{external, in ohms}) = \text{Signal voltage} * 100000 / \text{Suffix BBB voltage}$$

**GAIN MODE SELECT (P-I) JUMPER:** This jumper is a three position pin header and shorting bar located between the terminal block and the bracket. This jumper is used to select the amplifier gain mode. For all open loop applications as well as those closed loop systems that incorporate external transducers for position, pressure, force or torque feedback the gain mode select jumper should be set to the "P" or proportional position. For closed loop applications that utilize external transducers for flow or velocity control the gain mode select jumper should be set to the "I" or integral position.

**BIAS ADJUST CONTROL:** Use to set the output current to zero with a zero command signal applied. The "GAIN MODE SELECT" should be in the "P" position and no connection made to the "I" tabs when the bias is adjusted.

**GAIN ADJUST CONTROL:** Use to set the maximum output when the command signal is at maximum in open loop applications. Controls the amplifier stability in closed loop applications. Clockwise rotation will increase the output or decrease the stability.

**INHIBIT TABS (I) FUNCTION:** These tabs are generally used only in closed loop operations with integral gain. When they are shorted to each other the output from the internal integrator is forced to zero. This will prevent the amplifier from generating a false output signal due to mismatched or noisy input signals when the command signal is set to zero. During normal operation, their should be no connection between the tabs. The tabs must be left unconnected for all open loop applications.

**EXTERNAL WIRING:** External command signals should be twisted and shielded cable. All shields should be terminated at terminal 2 or 15 on the amplifier only. Do not expose or connect the shield at any point in its run from the signal source to the valve driver module. Connections to the valve coil need not be shielded, however a reasonable effort should be made to route this cable away from equipment generating electrical noise. For optimum performance, all external connections to the valve driver should be via shielded cable

## FUNCTIONAL DIAGRAM:

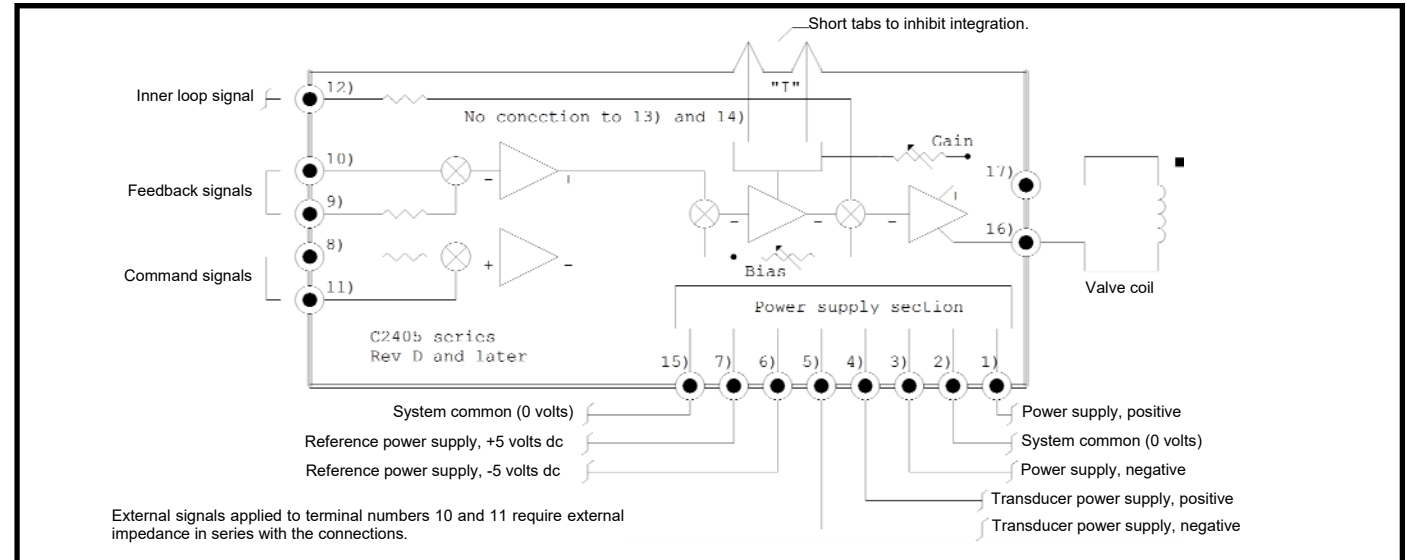

## !!!! CAUTION !!!!

The amplifier does not provide signal isolation. All power supply, command and feedback voltages must have the same common (0 volts) reference potential.

## APPLICATION EXAMPLES:

High performance, closed loop velocity control servo drive system. Amplifier uses the integral gain mode with the velocity feedback signal from a tachometer. The example uses the model series C2642 dither generator to improve performance and response.

